

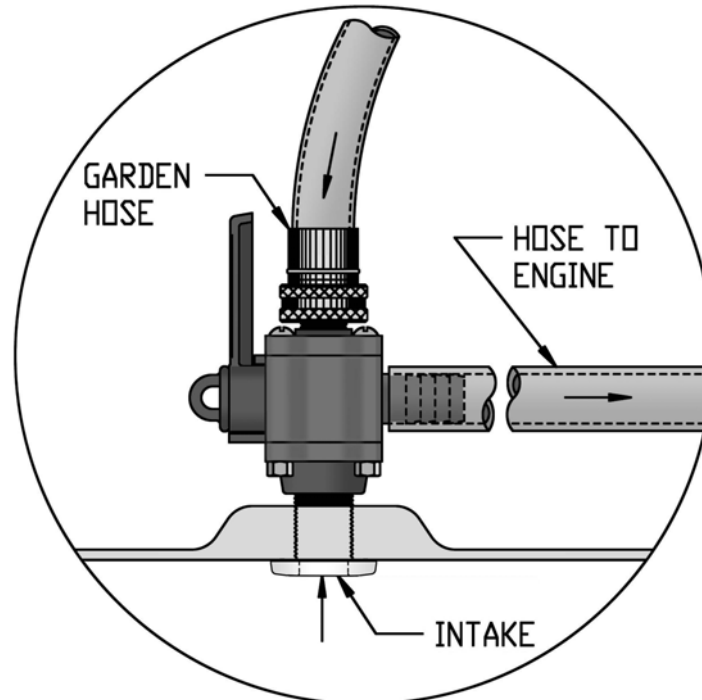

Fresh Water Flush Your Engine with Ease

With the Marelon[®] Engine Flush out Valve system, all it takes is a garden hose and the throw of a handle to run fresh water or anti-freeze through your inboard engine. The “Y” valve is built into the U.L. Approved seacock making this operation a breeze.



Regular fresh water flushing will extend the life of your engines cooling system. Now you can winterize easier and flush your engine regularly without the cumbersome changing of hoses, using pumps or other equipment. This Marelon[®] system makes it simple and fast.

- Marelon[®] seacock attaches to your existing thru-hull – Marelon[®] or bronze
- Simple re-routing of engine intake hose to valve barb
- Available in 1”, 1-1/4”, 1-1/2” and 2” hose sizes
- Marine U.L. Approved valve
- Makes engine winterizing easier, faster
- For any inboard engine on power or sailboats

Forespar[®]
22322 Gilberto
Rancho Santa Margarita, CA. 92688
Ph: 949-858-8820 Fax: 949-858-0505
sales@forespar.com www.forespar.com